

## 概述

这类J-FET 输入运算放大器专为低功耗应用而设计，它们的特点是高输入阻抗，低输入偏置电流和低输入失调电流。

先进的设计技术保证了更高的转换速率，增益带宽积和输出摆幅。商业和车辆设备可用塑料双列 DIP 直插和 SOP贴片封装。

TL061 单通道运算放大器，TL062 双通道运算放大器，TL064 四通道运算放大器。

## 主要特点

- 低电源电流：200uA/Amplifier
- 低输入偏置电流：5.0pA
- 高增益带宽：2.0MHz
- 高转换率：6.0V/uS
- 高输入阻抗：1012Q
- 大输出电压摆幅：±14V
- 输出短路保护

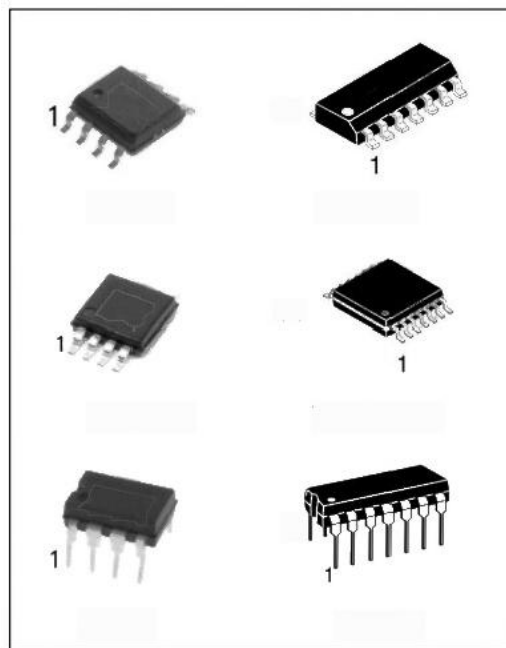

## 产品订购信息

产品名称	封装	打印名称	包装	包装数量
TL061CN	DIP-8	TL061C	管装	2000只/盘
TL061CM/TR	SOP-8	TL061C	编带	2500只/盘
TL061CMM/TR	MSOP-8	T061C	编带	3000只/盘
TL062CN	DIP-8	TL062C	管装	2000只/盘
TL062CM/TR	SOP-8	TL062C	编带	2500只/盘
TL062CMM/TR	MSOP-8	T062C	编带	3000只/盘
TL064CN	DIP-14	TL064C	管装	1000只/盘
TL064CM/TR	SOP-14	TL064C	编带	2500只/盘
TL064CMT/TR	TSSOP-14	T064C	编带	2500只/盘
TL061IN	DIP_8	TL0611	管装	2000只/盘
TL061IM/TR	SOP-8	TL0611	编带	2500只/盘
TL061IMM/TR	MSOP-8	T0611	编带	3000只/盘
TL062IN	DIP-8	TL062I	管装	2000只/盘
TL062IM/TR	SOP-8	TL062I	编带	2500只/盘
TL062IMM/TR	MSOP-8	T062I	编带	3000只/盘
TL064IN	DIP-14	TL064I	管装	1000只/盘
TL064IM/TR	SOP-14	TL064I	编带	2500只/盘
TL064IMT/TR	TSSOP-14	T064I	编带	2500只/盘

### 管脚排列图

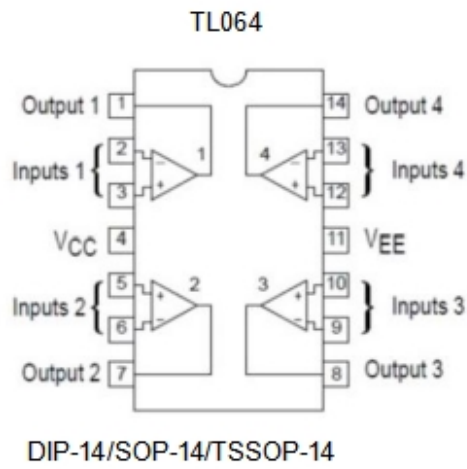
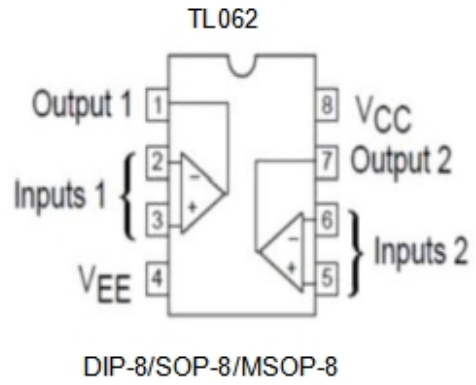
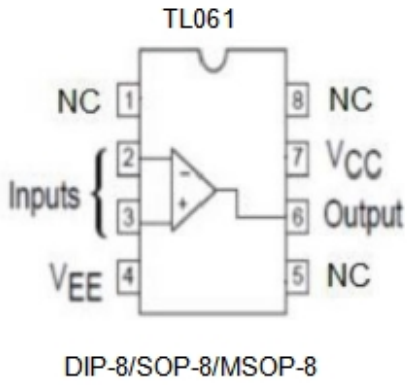

### 代表性示意图(每个放大器)

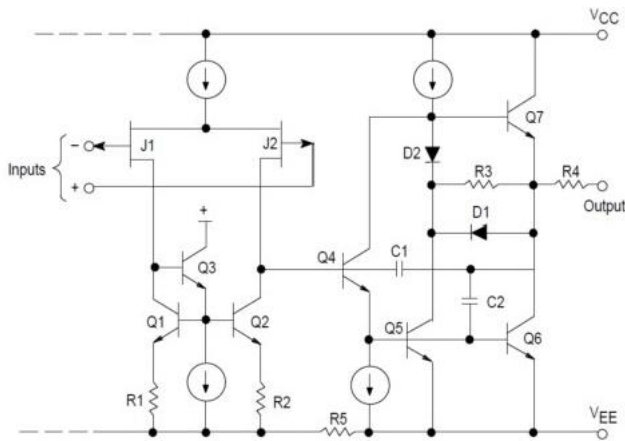

## 最大额定值(1)

类别	符号	值	单位
电源(从VCC到VEE)	VS	+36	V
输入差分电压范围(注2)	VDR	±30	V
输入电压范围(注2和注3)	VR	±15	V
输出短路持续时间(注4)	tsc	待定	sec
工作结温	TJ	+125	°C
工作温度 : TL061C, TL062C, TL064C	TA	0 to +70	°C
工作温度 : TL061I, TL062I, TL064I		-40 to +85	°C
存贮温度范围	Tstg	-60 to +150	°C
引脚温度(焊接10s)	TLEAC	<b>245</b>	°C

- 注：** 1、极限参数是指无论在任何条件下都不能超过的极限值。万一超过此极限值，将有可能造成产品劣化等物理性损伤；  
 同时在接近极限参数下，不能保证芯片可以正常工作。  
 2、差分电压相对于反相输入端子位于同相输入端。  
 3、输入电压的大小绝不能超过供电电压15伏的幅度，以较小者为准。  
 4、必须考虑功耗，以确保不超过最大结温。

**电 特 性 (Vcc=±15V, Tamp=25°C 特殊情况另外说明)**

参数	符号	TL061/TL062/TL064			单位
		Min	Typ	Max	
输入失调电压(RS=50Q, VO=0V) TA=25°C TA=0°C to +70°C	Vo		3.0	15 20	mV
偏移电压的平均温度系数 (RS=50Ω, VO=0V)	$\Delta V_{IO}/\Delta T$	—	10		uV/°C
输入失调电流(VCM=0V, VO=0V) TA=25°C TA=0°C to +70°C	Io		0.5	200 2	pA nA
输入偏置电流(VCM=0V, VO=0V) TA=25°C TA=0°C to +70°C	IB		3	200 10	pA nA
输入共模电压范围 TA=25°C	VICR	-11	+14.5 -12	+11	V
大信号电压增益(RL=10KQ, VO=±10 V0) TA=25°C TA=0°C to +70°C	Avol	3.0 3.0	EG		V/mV
输出电压幅度(RL=10KQ, VID=10 V0) TA=25°C TA=0°C to +70°C	Vo+ Vo-	+10	<b>+14</b> <b>-14</b>	-10	V
	Vo+ Vo-	+10		-10	
共模抑制比 (RS=50Ω, VCM=VICR min, VO=0V, TA=25°C)	CMR	70	<b>84</b>		dB
共模抑制比 (RS=50Ω, VCM=0V, VO=0V, TA=25°C)	PSR	70	<b>86</b>		dB
电源电流(每个独立运放) (空载, VO=0V, TA=25°C)	Io		<b>200</b>	250	uA
总功耗(每个独立运放) (空载, VO=0V, TA=25°C)	Po	—	6.0	7.5	mW

### 交流电气特性(VCC=+15V,VEE=-15V,TA=+25°C,除非特殊说明)

参数	符号	Min	Typ	Max	单位
转换速率 (Vin=-10V to +10V,RL=10kQ,CL=100pF,AV=+1.0)	SR	2.0	5.0		V/uS
上升时间(Vin=20mV,RL=10kQ,CL=100pF,AV=+1.0)	Tr		0.1		uS
偏离值 (Vin=20mV,RL=10kQ,CL=100pF,AV=+1.0)	OS		10		%
建立时间 (VCC=+15V,VEE=-15V,AV=+1.0,RL=10kQ,VO=0V to +10V step)	ts	To within 10mV To within 1.0mV	1.5 2.2		uS
增益带宽积 (f=200KHz)	GBW		2.0		MHz
等效输入噪声(RS=100Q,f=1.0KHz)	en		47		nV/sqrt(Hz)
输入电阻	Ri		1012		W
信道分离 (f=10KHz)	CS		120		dB

### 特性曲线

Figure 1. Maximum Power Dissipation versus Temperature for Package Variations

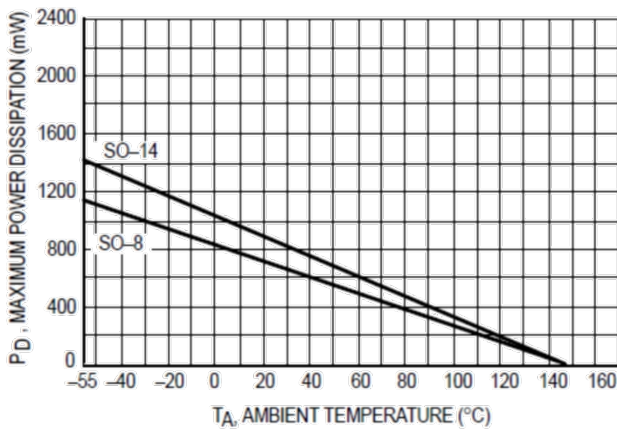

Figure 2. Output Voltage Swing versus Supply Voltage

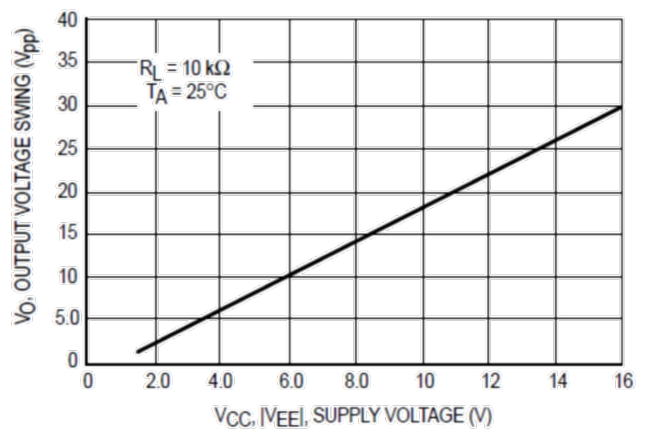

Figure 3. Output Voltage Swing versus Temperature

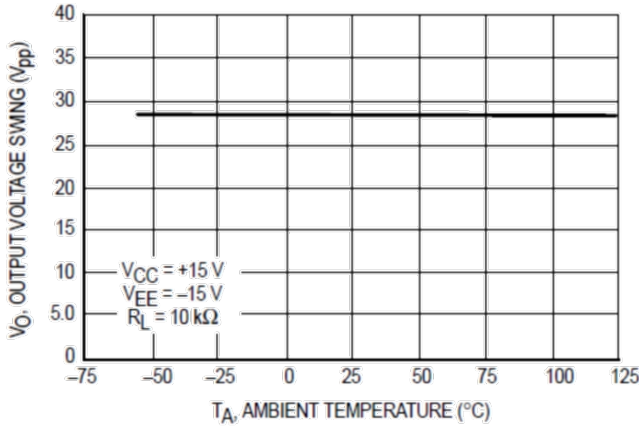

Figure 4. Output Voltage Swing versus Load Resistance

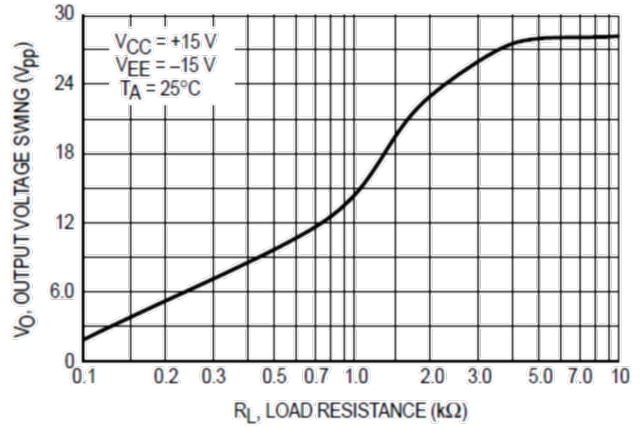

Figure 5. Output Voltage Swing versus Frequency

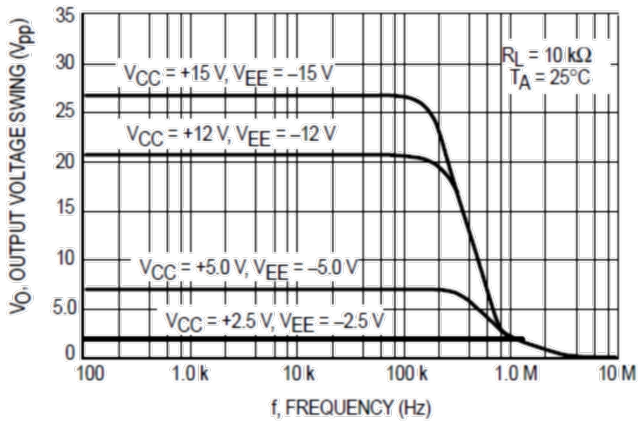

Figure 6. Large Signal Voltage Gain versus Temperature

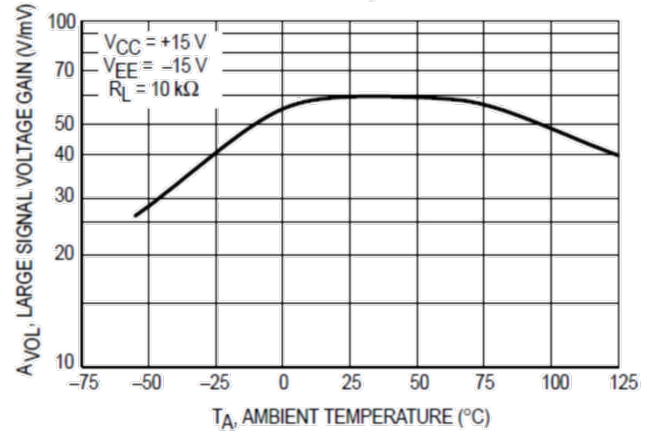

Figure 7. Open Loop Voltage Gain and Phase versus Frequency

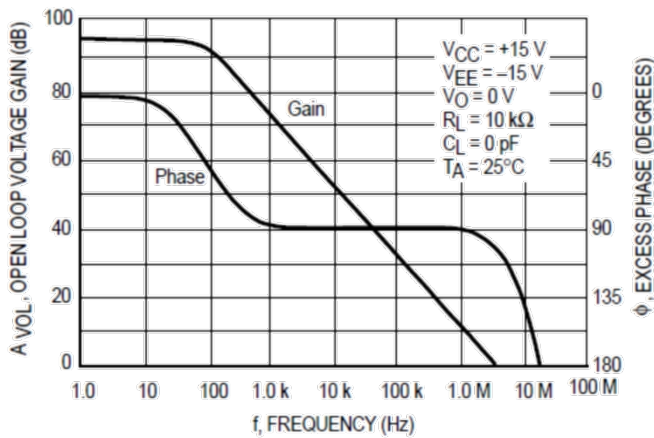

Figure 8. Supply Current per Amplifier versus Supply Voltage

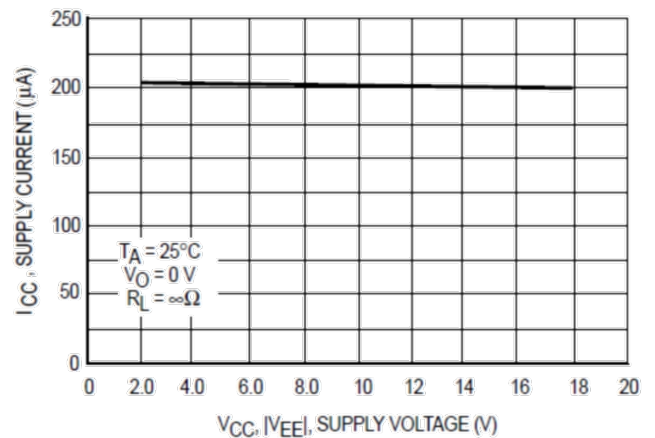



Figure 9. Supply Current per Amplifier versus Temperature

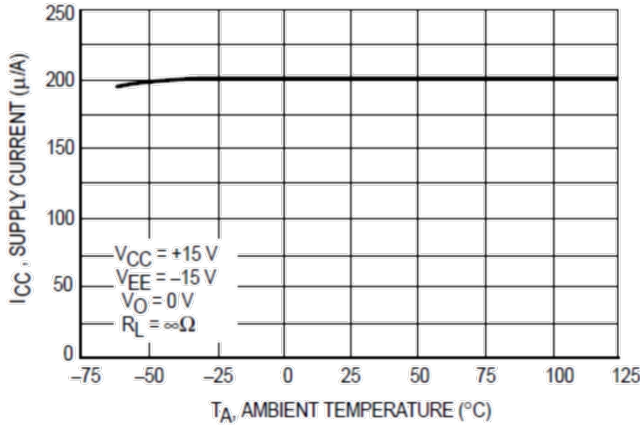

Figure 10. Total Power Dissipation versus Temperature

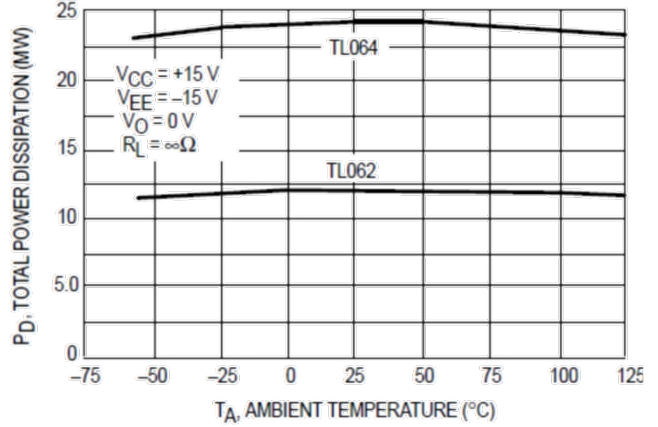

Figure 11. Common Mode Rejection versus Temperature

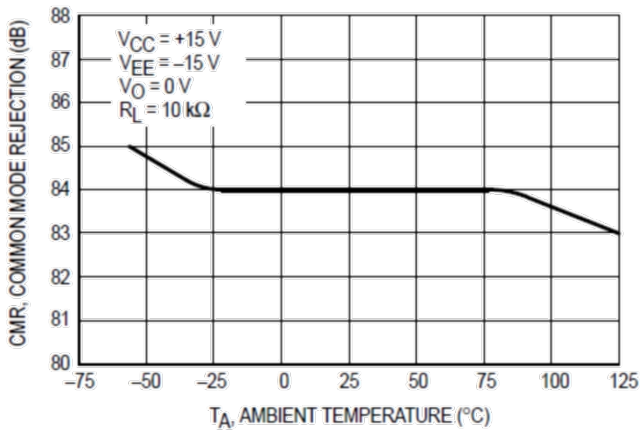

Figure 12. Common Mode Rejection versus Frequency

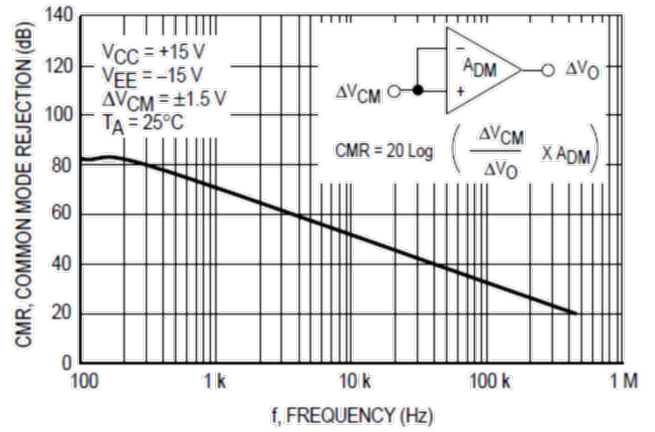

Figure 13. Power Supply Rejection versus Frequency

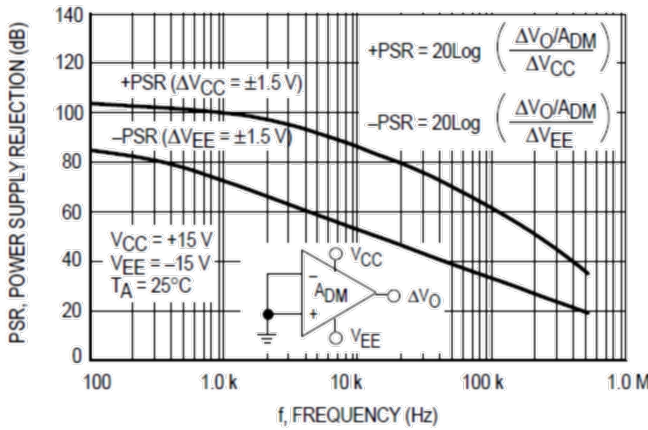

Figure 14. Normalized Gain Bandwidth Product, Slew Rate and Phase Margin versus Temperature

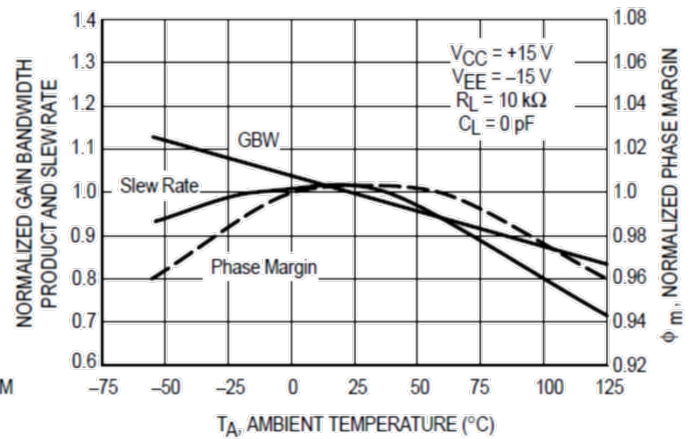

Figure 15. Input Bias Current versus Temperature

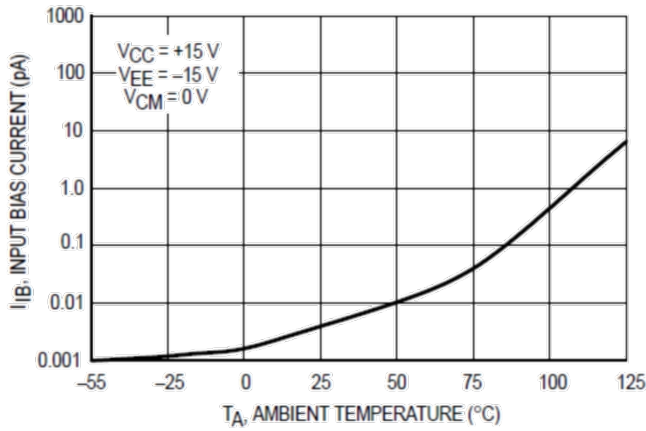

Figure 16. Input Noise Voltage versus Frequency

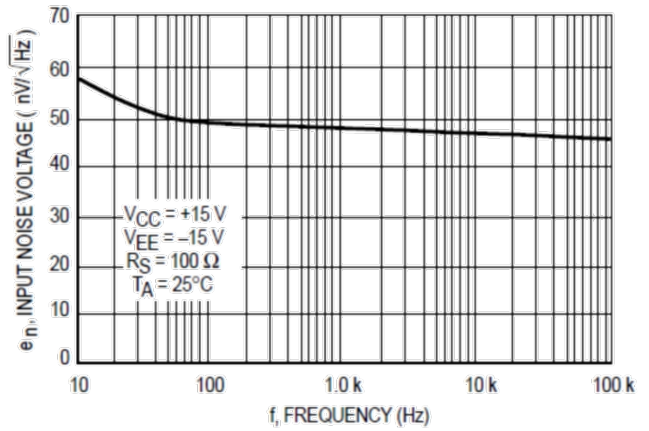

Figure 17. Small Signal Response

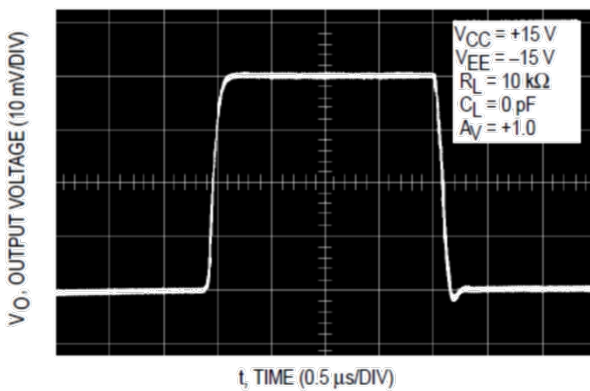
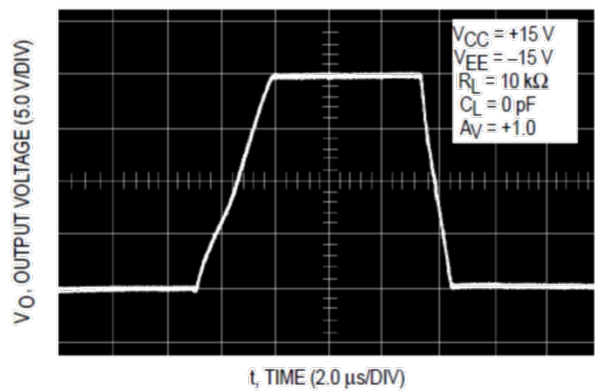

Figure 18. Large Signal Response



## 应用图

Figure 19. AC Amplifier

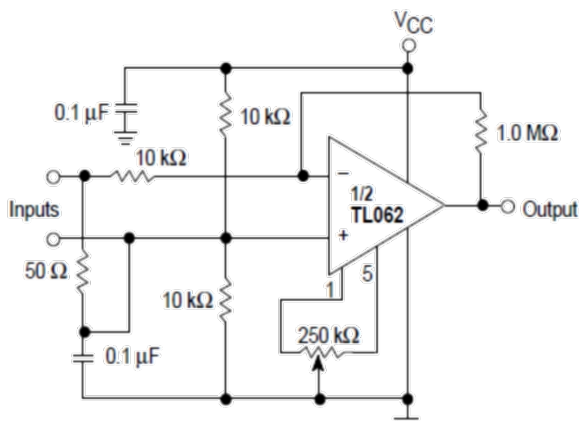

Figure 20. High-Q Notch Filter

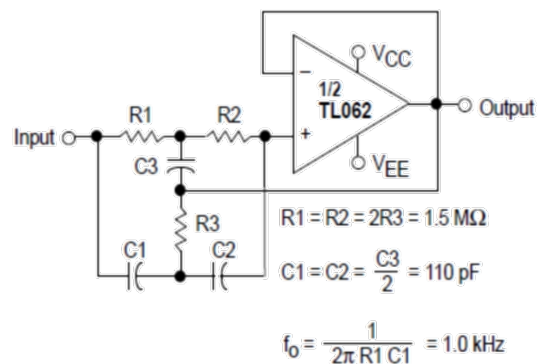



Figure 21. Instrumentation Amplifier

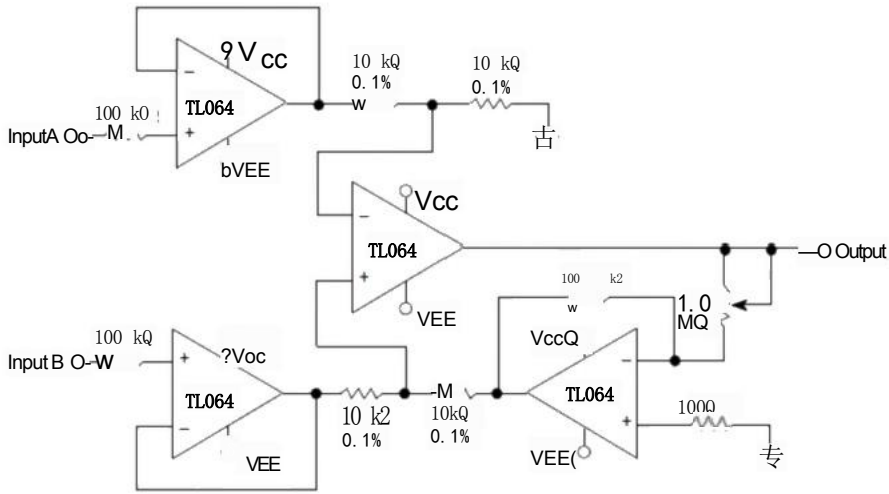

Figure 22

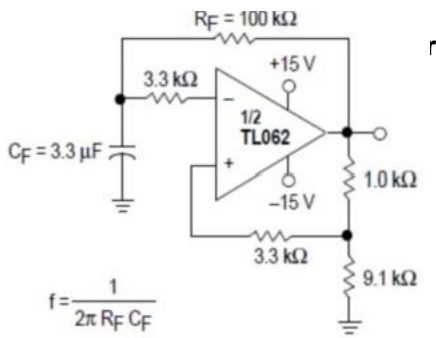
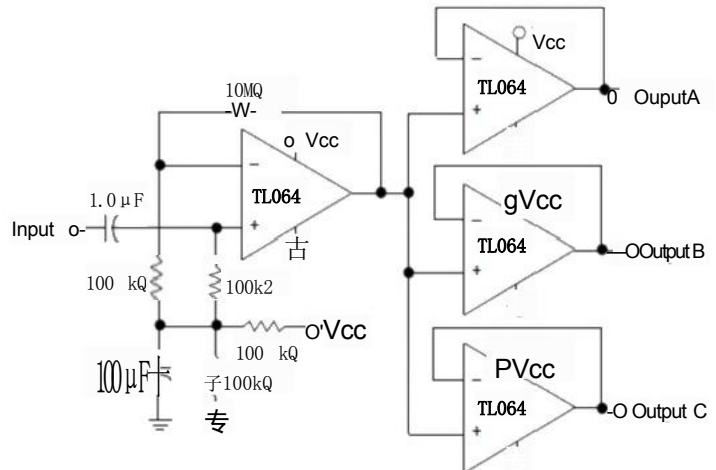
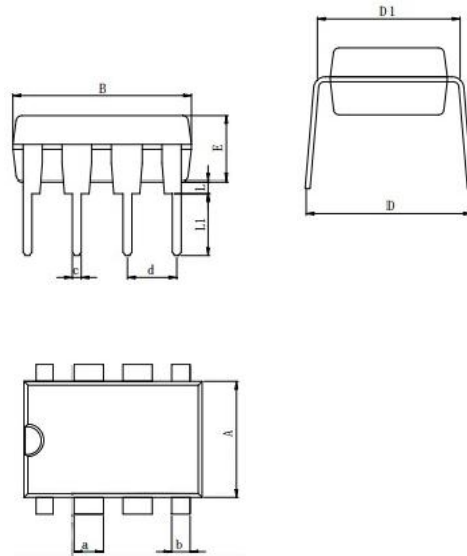

Figure 23. Audio Distribution Amplifier



封装外型尺寸  
DIP-8



Dimensions In Millimeters(DIP-8)

Symbol:	A	B	D	D1	E	L	L1	a	b	C	d
Min:	6.10	9.00	8.10	7.42	3.10	0.50	3.00	1.50	0.85	0.40	2.54 BSC
Max	6.68	9.50	10.9	7.82	3.55	0.70	3.60	1.55	0.90	0.50	

SOP-8 (150mil)

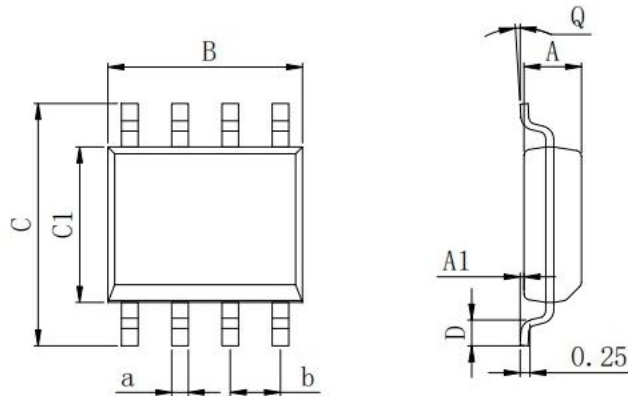

Dimensions In Millimeters(SOP-8)

Symbol:	A	A1	B	C	C1	D	Q	a	b
Min:	1.35	0.05	4.90	5.80	3.80	0.40	0°	0.35	1.27 BSC
Max	1.55	0.20	5.10	6.20	4.00	0.80	8°	0.45	

封装外型尺寸  
MSOP-8

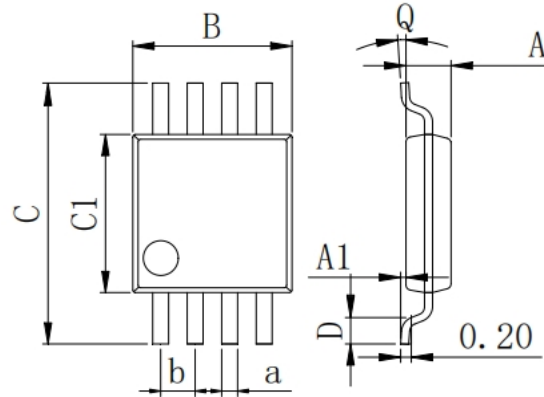

Dimensions In Millimeters(MSOP-8)									
Symbol:	A	A1	B	C	C1	D	Q	a	b
Min:	0.80	0.05	2.90	4.75	2.90	0.35	0°	0.25	0.65 BSC
Max:	0.90	0.20	3.10	5.05	3.10	0.75	8°	0.35	

DIP-14

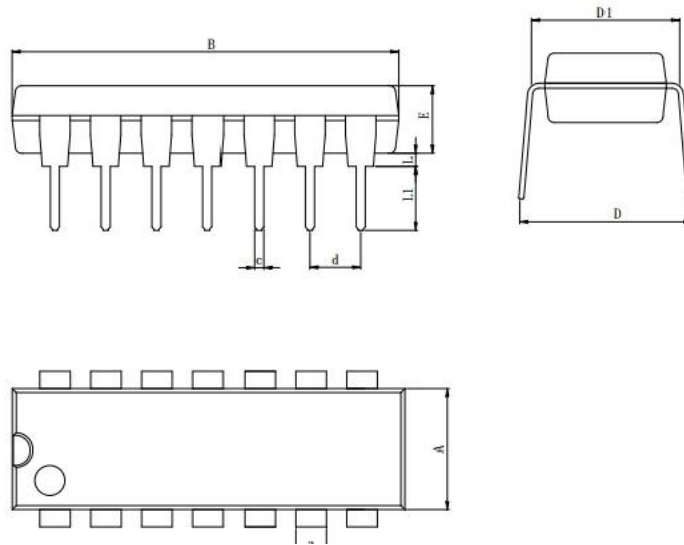

Dimensions In Millimeters(DIP-14)										
Symbol:	A	B	D	D1	E	L	L1	a	C	d
Min:	6.10	18.94	8.10	7.42	3.10	0.50	3.00	1.50	0.40	2.54 BSC
Max:	6.68	19.56	10.9	7.82	3.55	0.70	3.60	1.55	0.50	

**封装外型尺寸**  
**SOP-14**

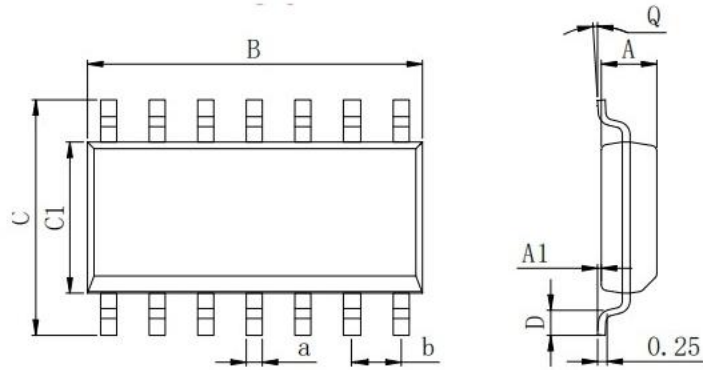

Dimensions In Millimeters(SOP-14)									
Symbol:	A	A1	B	C	C1	D	Q	a	b
Min:	1.35	0.05	8.55	5.80	3.80	0.40	0°	0.35	1.27 BSC
Max:	1.55	0.20	8.75	6.20	4.00	0.80	8°	0.45	

**TSSOP-14**

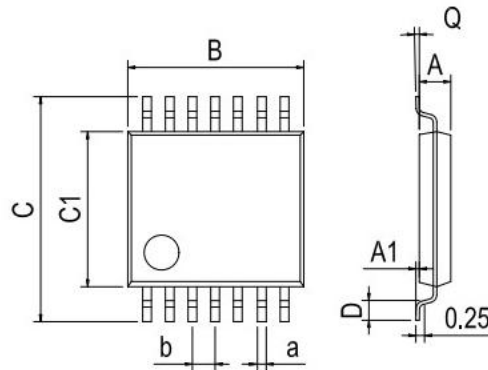

Dimensions In Millimeters(TSSOP-14)									
Symbol:	A	A1	B	C	C1	D	Q	a	b
Min:	0.85	0.05	4.90	6.20	4.30	0.40	0°	0.20	0.65 BSC
Max:	0.95	0.20	5.10	6.60	4.50	0.80	8°	0.25	